

**P.A. – S.p.A. – EQUIPAGGIAMENTI TECNICI DEL LAVAGGIO**

VIA MILANO, 13 – CASELLA POSTALE 115 – 42048 RUBIERA (REGGIO EMILIA) – ITALY  
 Tel. +39 0522 623611 – Fax. +39 0522 629600 – R.E.A. RE 156319 – R.I. RE11535 – Mecc. RE 013446  
 C.F. e P. IVA 01035950359 – Cap. Soc. i.v. € 750.000,00 – Codice Identificativo C.E.E. IT 01035950359  
 ART. 2497 – BIS C.C. DIREZIONE E COORDINAMENTO BENETTI srl R.I. TRIB. DI RE 01480690351  
 Web: <http://www.pa-etl.it> – E-mail: [info@pa-etl.it](mailto:info@pa-etl.it)



## FL3 – Electric signal flow switch

**Technical manual: E 803-04**

Electro-mechanical device in which the fluid passage moves a magnetized piston that closes an electric circuit.

**DN10**

- **28.0500.10** G3/8 MM
- **28.0530.10** G3/8 MM + G1/4 F
- **28.0540.10** G3/8 MM Magnetholder OT

- Reed switch with high resistance.
- Electrical insulation: class **IP55**
- Reduced dimensions both axial and lateral.
- Magnetic drive obtained by the plunging piston movement.
- Magnet covered by plastic casing to minimize the braking effect of metal particles and scale.
- Wire for earth
- \* Version with 1/4 Bsp gauge port.

### TECHNICAL SPECIFICATIONS

Rated voltage:	<b>12 ÷ 230 V AC/DC</b>	Max commutable power :	<b>60VA</b>
Cable length:	<b>1250 mm</b>	Electric wire:	<b>2 x 0,50mm<sup>2</sup></b>
Ambient temp:	<b>75°C</b>	Type of action:	<b>1C</b>
Max current:	<b>3 A</b>		

Electrical component life: from 100.000 to 1.000.000 commutations at max power.  
 Pollution situation of the device control: High

PART NUMBER	RATED PRESSURE bar - MPa	PERMISSIBLE PRESSURE bar - MPa	MAX FLOW RATE l/min	MIN FLOW RATE INTERVENT. l/min	MAX TEMP FLUID °C	WEIGHT g
<b>28.0500.10</b>	250 - 25	280 - 28	30	3	(1) 75	275
<b>28.0540.10</b>	250 - 25	280 - 28	30	3	(2) 75	290
<b>28.0530.10*</b>	250 - 25	280 - 28	30	3	(1) 75	290
<b>28.0535.00*</b>	250 - 25	280 - 28	30	3	(2) 75	305

**\* Version with 1/4Bsp gauge port**

(1) The flow switch has been designed for a continuous use at a water temperature of 50°C. It can resist for short periods at a maximum temperature of 75°C.

(2) The flow switch has been designed for a continuous use at a water temperature of 75°C

## DIMENSIONAL DRAWING

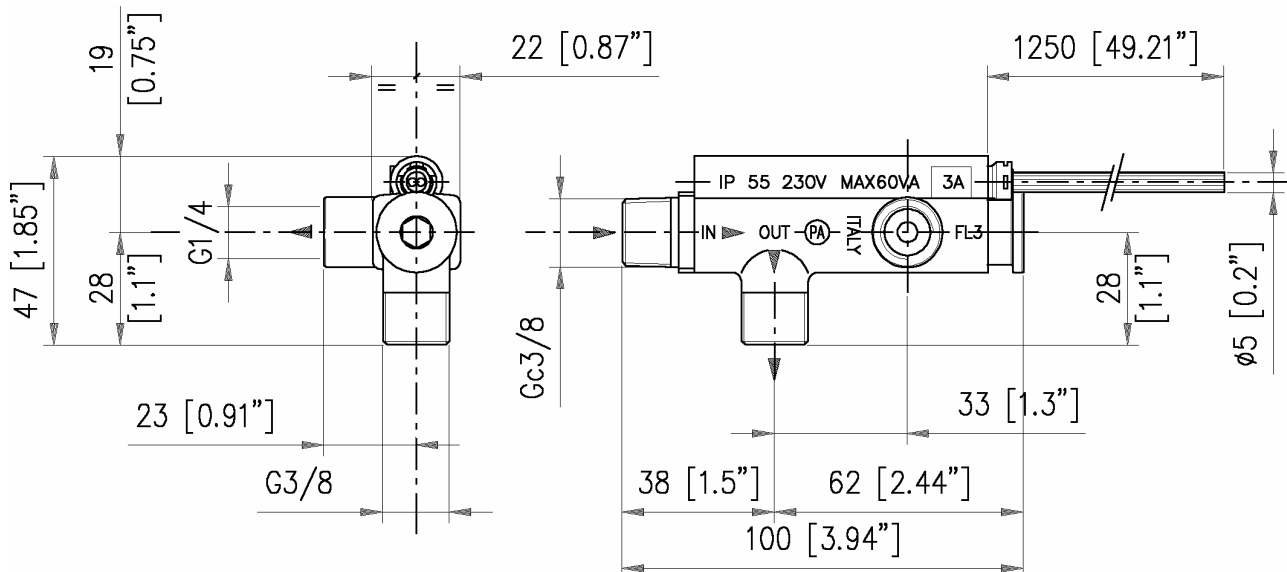

## INSTRUCTIONS

### SELECTION

This product is to be utilized with clean fresh water, even slightly additivated with normal detergents. For use involving different or corrosive liquids, contact the PA Technical department.

Choose the flowswitch in line with the data of nominal running (system rated pressure, max flow and max temperature). In any case, the pressure of the machine should not exceed the permissible pressure rate imprinted on the body.

Check the real value of voltage and current of the system: they should be kept within the max indicated value.

### INSTALLATION

#### Connection to the Hydraulic system.

Use correct fittings in line with the dimensions and performance of the valve. Avoid restrictions on the passage diameters that might cause malfunctions, pressure reduction and wearing. This accessory, on a system that produces hot water, must be fitted in **front of the generator**.

**Attention: on the stud G1/4F, flowswitch FL3 PN 28.0530.00, fit only pressure tracking devices like pressure switches and pressure gauges. DO NOT FIT ANY SAFETY VALVES.**

This product is to be installed on a finished machine.

#### Electric installation

For the connection of the electric installation, **see fig.1**

Electrical installation is to be carried out by **qualified personnel**.

**CAUTION!! - The electric device must be mounted on an earthed hydraulic system.**

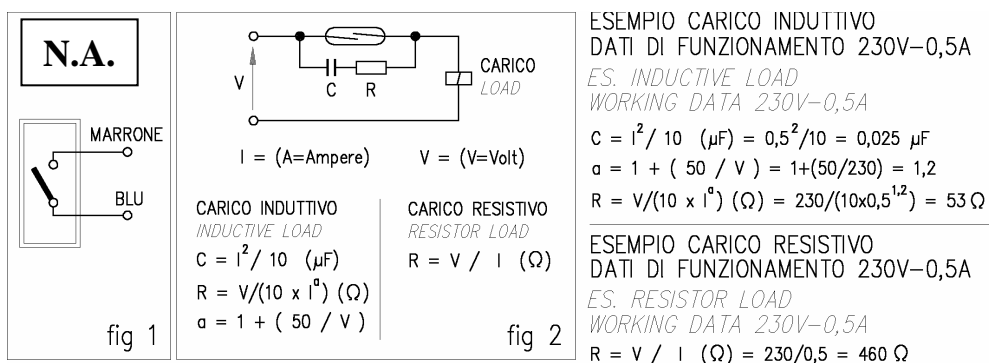

## ELECTRIC LIFETIME OF THE CONTACT

The electric circuit, contained in the probe, consists of a reed switch that can function up to 1 million operations. Current or voltage in excess, superior to the allowed limits, damage considerably the contacts reducing the electric lifetime (pitting; sticking). To prevent these phenomena, it is necessary to evaluate with attention the transient ratings in which the take off current might be 10/12 times the rating current.

## OPERATIONS

In order to prevent malfunctions, the flow switch must not be set near heat or magnetic sources. Do not store or handle on full metal structures nor test the magnetic strength of the piston on magnetic material. It is advisable to properly clean the system before operation in order to expell possible residual metal. The electric probe is stamped at the end of the exit cable, indicating the setting in relation to the brass body and allows a correct assembly of the "reed" bulb. In case of intervention or repair, **follow this indication**: wrong positioning could damage the probe.

## PROBLEMS AND SOLUTIONS

PROBLEMS	PROBABLE CAUSES	SOLUTIONS
The Piston does not move	<ul style="list-style-type: none"> <li>- Insufficient flow</li> <li>- Faulty assembly</li> <li>- Piston jammed by scale and metal shavings</li> </ul>	<ul style="list-style-type: none"> <li>- Check leaks in the circuit</li> <li>- Re-assemble, observing the flow direction</li> <li>- Check, clean and/or replace</li> </ul>
Electric signal missing	<ul style="list-style-type: none"> <li>- Damaged "reed" electric contacts</li> <li>- Electric connection incorrect or disconnected</li> <li>- Un-phased probe or displaced</li> </ul>	<ul style="list-style-type: none"> <li>- Replace electric probe</li> <li>- Provide eventual circuit protection</li> <li>- Check and/or repair</li> <li>- Renew</li> </ul>

## REGULATIONS :

The accessory hereby described bears the CE marking in accordance with the Norms and Directives applied on the **Declaration of Conformity**.

For a correct utilization, follow the directions described in this manual and re-print them on the Use and maintenance manual of the machine

Make sure that you are given the Original Conformity Declaration for the accessory chosen. The present manual is valid for all Flowswitches named **FL3**

## SPARES

Use only original PA spares, in order to benefit for a correct function and long reliability.

## MAINTENANCE

Maintenance has to be carried out by **Specialized Technicians**.

Every 400 working hours (circa 10,000 cycles) check the magnetic pin (pos 3) and clean.

For a correct assembly, follow the phases indicated on the exploded view referred.

**The Manufacturer is not to be considered responsible for damage as a result from incorrect fitting and maintenance.**

Technical data, descriptions and illustrations are indicative and liable to modification without notice.

<b>Instruction manual, maintenance, installation, spare parts.</b> <u>For a correct utilization follow the directions of this manual.</u> <b>Re-print them on the use and maintenance booklet of the machine.</b>	n. 12.9803.04

28.0500.10 FL3 Flow switch 3/8MM Bsp  
 28.0530.10 FL3 Flow switch 3/8MM +1/4F Bsp

28.0540.10 FL3-2 FI.switch 3/8MM Bsp brass pist.

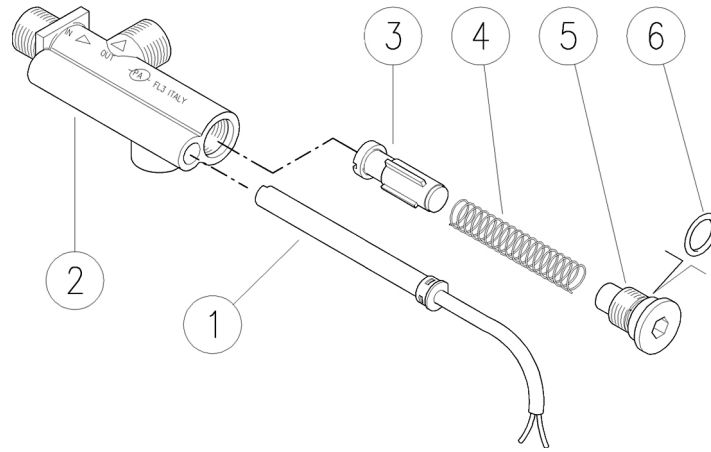

Pos.	P/N	Description	Q.ty	K1	K2	K3	K4		Pos.	P/N	Description	Q.ty	K1	K2	K3	K4	
1	28.0518.23	Feeler, 3A +1250 mm cable	1					5	3	28.0508.23	Magnet holder, brass (2)	1					5
2	28.0501.35	FI/sw. housing, 3/8MBsp -3/8M Bspt brass	1					3	4	28.0505.51	Spring, 0,7x11,7x52 mm Sst.	1					5
2	28.0531.35	FI/sw.hous., 3/8M Bsp-3/8M Bspt-1/4F brs (1)	1					3	5	28.0517.31	Plug -fl/sw., M14x1 brass	1					5
3	28.0502.23	Magnet holder,plast. POM	1					5	6	10.3059.01	O-ring, 1,78x11,11 mm Ni 85	1					10

(1) 28.0530.10 (2) 28.0540.10